

TYPE: LMP

LMP Stainless Steel Load Measuring Pin



Description

The LCM range of load measuring pins are designed for general use. They are a simple and versatile type of load cell that are used in a large variety of applications such as cranes, winches, hoists, load shackles and bearing blocks. They are easily installed into machines by replacing any existing load bearing pin to provide accurate, real time monitoring of load forces.

Machined from high tensile stainless steel and normally supplied complete with an anti-rotation plate, our load measuring pins are built to exacting standards and proof loaded to 150% of normal rated load. Our standard load pin range covers ratings between 500kgs and 1500 tonnes, and can be provided as shown on this data sheet or can be modified to meet a particular application requirement (see LPB data sheet)

The LMP series can be supplied on its own or combined with our extensive range of instrumentation to provide a complete load monitoring system.

Specification

Rated load (tonne)	0.5, 1, 2.5, 3.5, 6.5, 15, 25, 50, 100, 250, 500, 750, 1000, 1500
Proof load	150% of rated load
Ultimate breaking load	>300% of rated load
Output	1.5mV/V at rated load (nominal)
Non-linearity	<±1.0% of rated load (typically)
Non-repeatability	<±0.1% of rated load
Excitation voltage	10vdc recommended, 15vdc maximum
Bridge resistance	350Ω
Insulation resistance	>500MΩ @ 500vdc
Operating temperature range	-20 to +70°C
Compensated temperature range	-10 to +70°C
Zero temperature coefficient	<±0.01% of rated load/°C
Span temperature coefficient	<±0.01% of rated load/°C
Environmental protection level	IP67
Connection type	5 metre 4-core screened PUR cable
Wiring connections	+ve supply: Red -ve supply: Blue +ve signal: Green -ve signal: Yellow

Available Options

- Integral signal conditioning
- Special electrical connectors
- Anti-rotation plate
- TEDS option (when used with TR150 handheld display)
- Submersible versions available (see LPB data sheet)

Features

- Ranges: 500kg to 1500 tonne
- Stainless steel construction
- Environmentally sealed to IP67
- Anti-rotation plate supplied if required
- Can be supplied with integral connector
- Versions available with integral conditioning providing 0-10v, 0.5v, 4-20mA, RS485 outputs
- Design support software available

Typical Applications

- Crane overload protection
- Winch force monitoring
- Cable and wire dynamometers
- Hoist overload protection
- Mooring load tension measurement

LCM Systems Ltd

Unit 15, Newport Business Park
Barry Way, Newport
Isle of Wight PO30 5GY UK
Tel: +44 (0)1983 249264
Fax: +44 (0)1983 249266
sales@lcmssystems.com
www.lcmssystems.com

TYPE: LMP

LMP Stainless Steel Load Measuring Pin

Dimensions

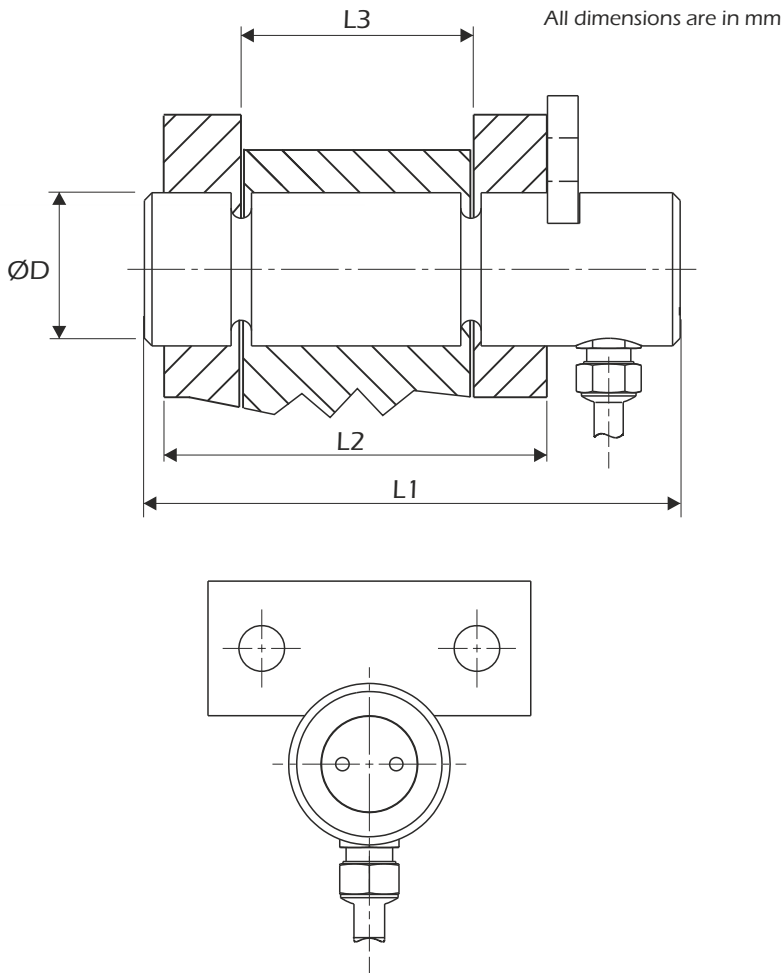

Rating (tonnes)	Part No.	ØD	L1	L2	L3	Weight (kgs)	Resolution (tonnes)
0.5	LMP-20-36	20	70	36	24	0.9	0.002
1	LMP-20-49	20	80	49	35	1	0.005
2.5	LMP-25-70	25	100	70	45	1.2	0.01
3.5	LMP-30-75	30	105	75	50	1.4	0.02
6.5	LMP-40-95	40	125	95	63	2	0.02
15	LMP-50-114	50	150	114	75	3.1	0.05
25	LMP-63-152	63	195	152	89	5.6	0.1
50	LMP-75-175	75	225	178	102	8.6	0.2
100	LMP-88-190	88	230	190	110	11.8	0.5
200	LMP-125-220(200)	125	300	220	130	29.8	1
250	LMP-125-220	125	300	220	130	29.8	1
500	LMP-170-370	170	440	370	225	79.2	2
750	LMP-200-500	200	590	500	295	146	2
1000	LMP-250-612	250	712	612	360	275	5
1500	LMP-275-731	275	832	731	430	389	5

www.lcmsystems.com



SCIGATE AUTOMATION (S) PTE LTD

No.1 Bukit Batok Street 22 #01-01 Singapore 659592

Tel: (65) 6561 0488

Fax: (65) 6562 0588

Email: sales@scigate.com.sg

Web: www.scigate.com.sg

Business Hours: Monday - Friday 8.30am - 6.15pm

Due to continual product development, LCM Systems Ltd reserves the right to alter product specifications without prior notice.

Issue No. 1

Issue date: 05/12/2014

APPROVED

(unapproved if printed)